

Application for City Building Permit

TO THE ENFORCING OFFICER OF NAPOLEON, OHIO

Application No. 351 Date 5-2-60

NAME OF APPLICANT EDWIN ZENZ PHONE _____

ADDRESS 433 E. MAIN. NAME and ADDRESS of OWNER JAM E

510 W. Riverview Ave IN ANTHONY WAYNE ACRES

LOCATION OF PROPERTY — LOT NO. 3 ADDITION

STREET NO. or OTHER DESCRIPTION OF LOCATION _____
R.F.D. 2 RIVERVIEW AVE

PRESENT USE OF PROPERTY VACANT PROPOSED USE RESIDENCE

ZONING CLASS OF PROPERTY A

CONTRACTOR HOWARD MITCHELL ADDRESS NAPOLEON

SHOW ALL DETAILS ON SKETCH BELOW

Estimated Cost 16,000 00
Lot Dimensions 135 x 210
Lot Area, Sq. Ft. 28,350
+ 3 x 28
30 x 64
Bldg. Size _____
Sq. Ft. 2060
Front Yard 40'
Side Yard 71'
Off St. Parking YES
Off St. Loading BRICK
Type Of Const. * FRAME
 New Addition
Location Of Sewer or _____
Septic Tank REAR
Location Of Water Tap STREET

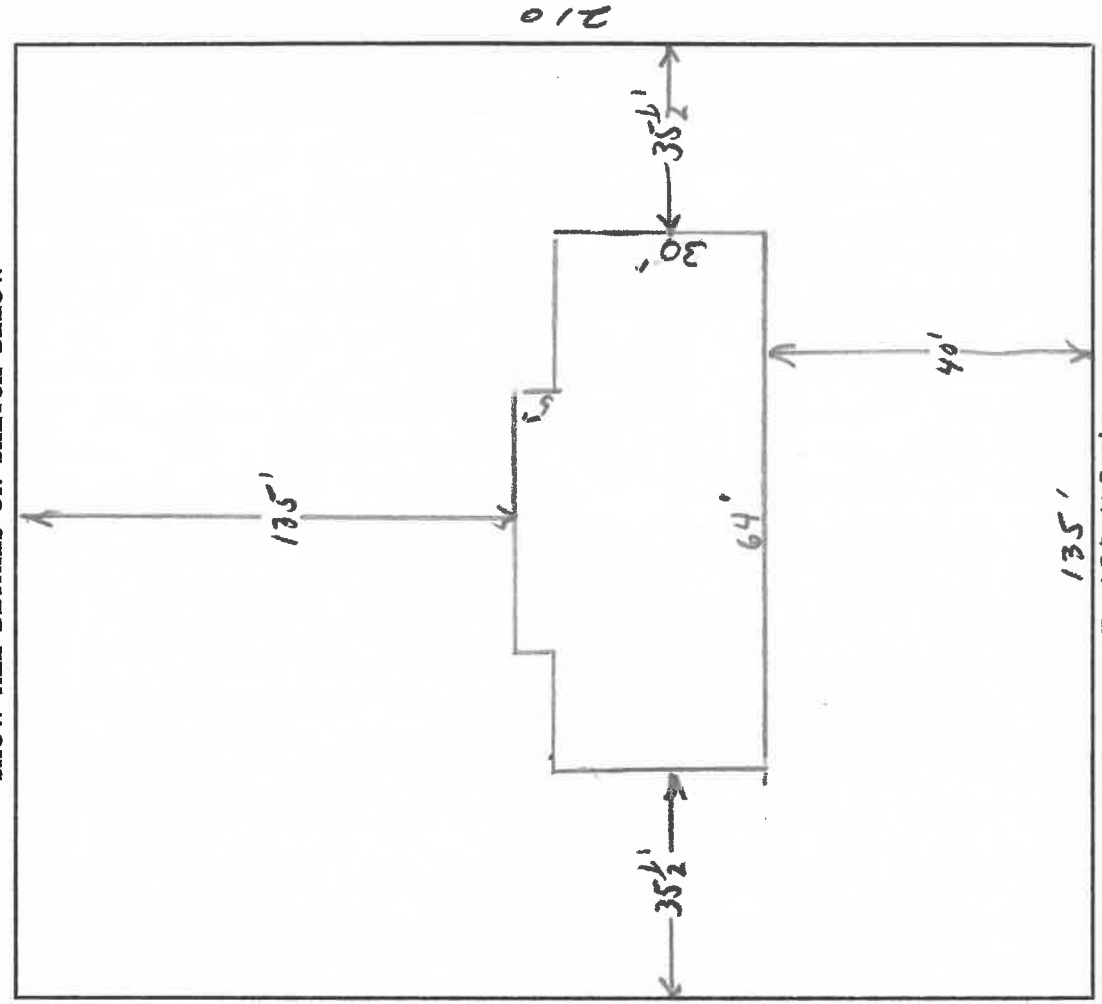

BUILDING PERMIT NO. 351 ISSUED 5-2-60 RIVERVIEW DENIED

IF DENIED, STATE REASONS _____

CERT. OF OCCUPANCY NO. _____ ISSUED _____ INSP. DATE _____

IF DENIED — STATE REASONS _____

BOARD ACTION REQUESTED _____ COMM. ACTION REQUESTED _____

I hereby declare that the above and attached information is correct, and agree, in consideration of and upon issuance of a building permit, to do or allow to be done only such work as herewith applied for and such premises and its existing and proposed buildings and structures shall be used or allowed to be used for such purposes as set forth above.

Signed by Edwin Zenz Address _____
who hereby declares that he has been duly authorized by the Owner/Lessee to make the above application and agreement.